

TECHNICAL SUPPLEMENT

JAMES HARDIE SCYON™ AXON™ CLADDING

SEPTEMBER 2006

Structural Bracing

INTRODUCTION

All buildings require bracing against lateral forces due to wind forces or racking shear. This technical supplement outlines how to achieve the necessary bracing requirements in timber framed houses using Scyon™ Axon™ cladding fixed direct to timber frame.

This technical supplement must be read in conjunction with the current James Hardie Scyon Axon cladding installation instructions and Structural Bracing Design Manual. Additional design and installation requirements are detailed in these documents which must be complied.

NOMINAL BRACING

Table 1 provides the Ultimate Limit State (ULS) design capacities for Scyon Axon cladding when installed to timber framing in accordance with AS 1684 'Residential Timber Framed Construction'. Refer to Section 2 of the current Structural Bracing Design manual for more information.

TABLE 1

ULS DESIGN BRACING CAPACITY FOR SCYON™ AXON™ CLADDING (See notes below)		
FIXING METHOD		BRACING CAPACITY (kN/m)
1	Scyon Axon sheets fixed directly to frame with 2.8 x 40mm fibre cement nails, see Figure 1.	5.0
2	Scyon Axon sheets fixed directly to frame with ND 50mm 14 gauge 304 stainless steel brad nails, see Figure 2.	3.5

NOTES FOR TABLE 1

1. ND 50mm 14 gauge 304 stainless steel brad nails are only suitable for wind classifications N1, N2, N3, and C1. For more information refer to the Scyon Axon cladding installation instructions.
2. If the bracing panel occurs in isolation within a length of wall and is not connected to any cross-wall, then the capacity given in Table 1 must be reduced by 30%.
3. If JD5 grade timber is used in the framing, then the capacity given in Table 1 must be reduced by 12.5%.
4. Depending on the project's wind classification, closer sheet fixing centres may be required compared to Figures 1 and 2, refer to Table 2 in the current Scyon Axon installation instructions for more information.

WALL HEIGHT REDUCTION

The capacity of Scyon Axon clad walls given in Table 1 are for a standard wall height up to 2700mm and decreases as the wall height increases. Refer to Clause 8.3.6.4 of both Parts 2 and 3 of AS 1684, interpreted in Table 2 of the Structural Bracing Design manual.

For information on product installation, warranties and maintenance requirements refer to www.jameshardie.com.au or Ask James Hardie™ on 13 11 03.

Ask James Hardie™

CUSTOMERLINK® SERVICE CENTRE

Call 13 11 03

www.jameshardie.com.au

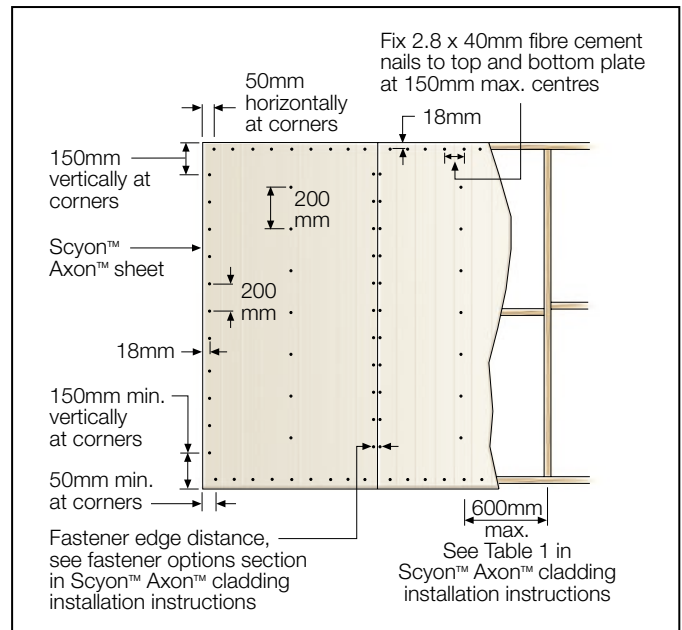

FIGURE 1 FIXING METHOD 1 FASTENER LAYOUT

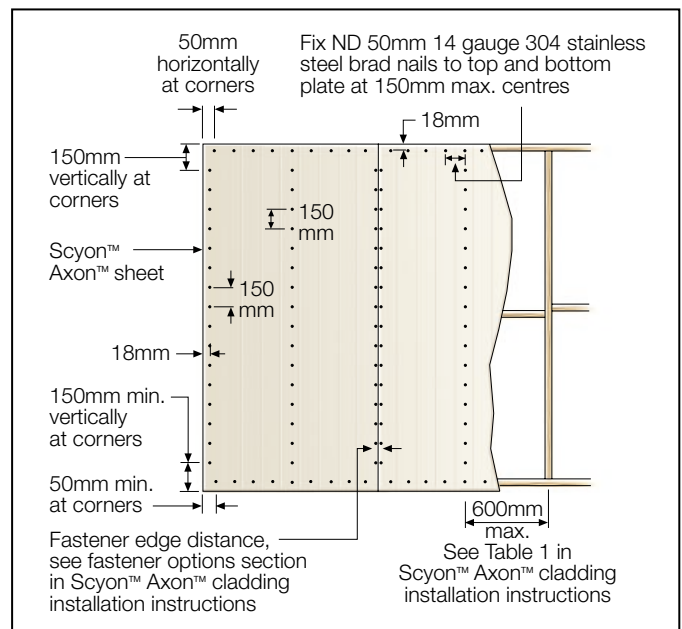

FIGURE 2 FIXING METHOD 2 FASTENER LAYOUT

